

THIS DOCUMENT CONTAINS PROPRIETARY INFORMATION AND SUCH INFORMATION MAY NOT BE DISCLOSED TO OTHERS FOR ANY PURPOSE OR USED FOR MANUFACTURING PURPOSES WITHOUT WRITTEN PERMISSION FROM AEROTRONICS, INC.

REVISIONS			
REV		DATE	APPRV'D
NC2	PRELIMINARY	09/21/20	LAV

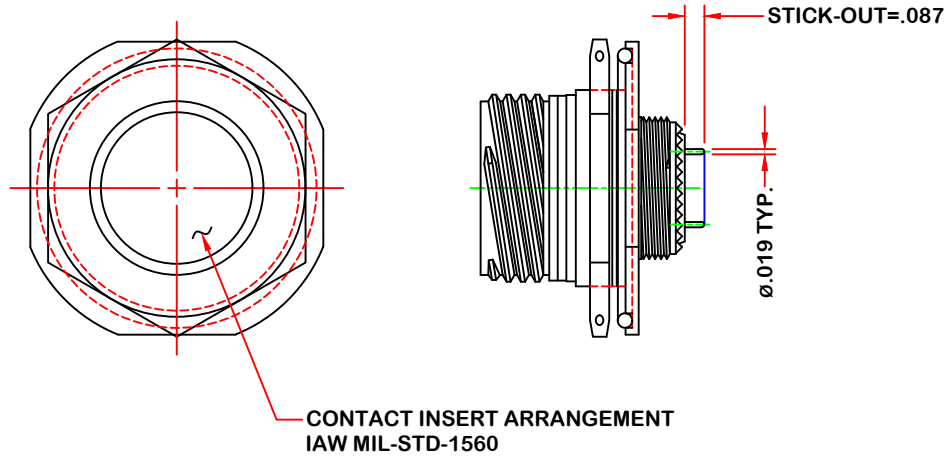

A24WC35PA-2212-360T

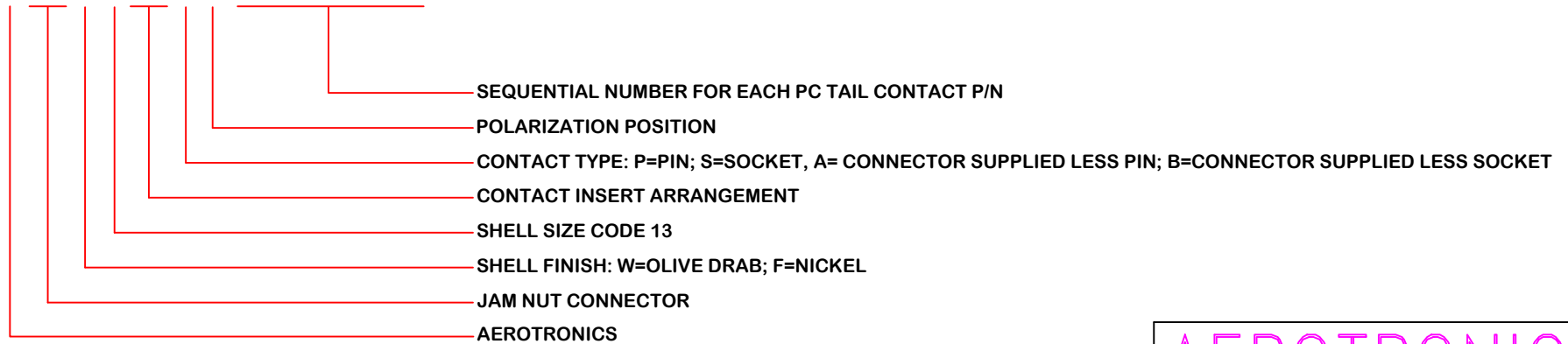

5. CONNECTORS SHALL BE MARKED WITH MIL PART NUMBERS.
 4. SUFFIX "T" AT THE END OF CONTACT P/N DENOTES TIN DIPPING.
 3. PIN CONTACT P/N 4511-2212-360T.
 2. CONTACTS IAW MIL-C-39029/58-360, PC TAIL.
 1. CONNECTOR SHALL MEET ALL APPLICABLE REQUIREMENTS IAW D38999/24.
- NOTES: UNLESS OTHERWISE SPECIFIED

DO NOT SCALE PRINT	
UNLESS OTHERWISE SPECIFIED DIMENSIONS ARE IN INCHES	
TOLERANCES:	ANGLES: ±2°
DECIMALS:	
.XX ±.01	
.XXX ±.005	
.XXXX ±.0005	

AEROTRONICS	
CONNECTOR, ELECTRICAL, RECEPTACLE, SERIES III (MIL-C-38999)	
CUSTOMER DRAWING	
DWG NO.	CAGE CODE
A24WXXXPX-2212-360T	1B6X9
SCALE: --	REV.
DATE: 08/10/20	NC2
PAGE: -	