

THIS DOCUMENT CONTAINS PROPRIETARY INFORMATION AND SUCH INFORMATION MAY NOT BE DISCLOSED TO OTHERS FOR ANY PURPOSE OR USED FOR MANUFACTURING PURPOSES WITHOUT WRITTEN PERMISSION FROM AEROTRONICS, INC.

REVISIONS			
REV		DATE	APPRV'D
NC	PRELIMINARY	03/09/22	LAV

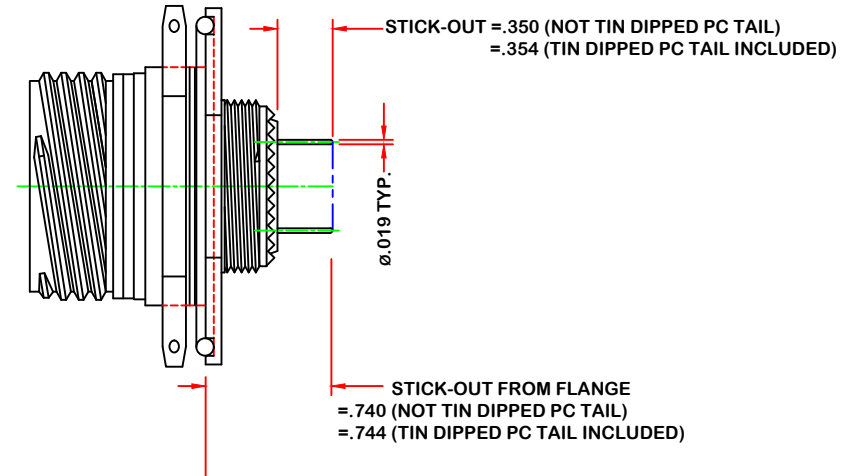
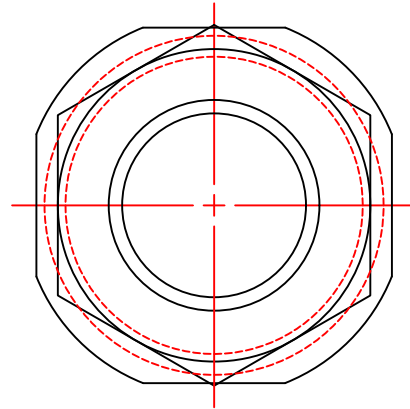

### ATV07RW-23-151SN-2300-172(T)

- SEQUENTIAL NUMBER FOR EACH PC TAIL CONTACT P/N
- POLARIZATION POSITION
- CONTACT TYPE: SOCKET
- INSERT ARRANGEMENT
- SHELL SIZE
- CORROSION RESISTANT, OLIVE DRAB CADMIUM PLATE ALUMINUM.
- SHELL STYLE: JUM NUT RECEPTACLE
- TRI-START SERIES CONNECTOR
- AEROTRONICS

4. CONNECTORS SHALL BE MARKED WITH MIL PART NUMBERS.
  3. SUFFIX T" AT THE END OF CONTACT P/N DENOTES TIN DIPPING.
  2. SOCKET CONTACT P/N 3510-2300-172 PC TAIL PER IAW MIL-C-39029/17-172.
  1. CONNECTOR SHALL MEET ALL APPLICABLE REQUIREMENTS MIL-DTL-38999 HIGH DENSITY.
- NOTES: UNLESS OTHERWISE SPECIFIED

DO NOT SCALE PRINT  
 UNLESS OTHERWISE SPECIFIED  
 DIMENSIONS ARE IN INCHES  
 TOLERANCES:  
 DECIMALS: ANGLES: ±2'  
 .XX ±.01  
 .XXX ±.010  
 .XXXX ±.0005

**AEROTRONICS**

CONNECTOR, ELECTRICAL, JUM NUT RECEPTACLE

DWG NO. <b>ATV07RW-23-151SX-2300-172</b>	REV. NC
SCALE: --   DATE: 03/09/22   PAGE 1 of 1	